

HTC9



CATEGORY TOPAZ CAFÉ RANGE

RANGE **Topaz Cake Display**

UNIT REFRIGERATOR

TYPE SELF CONTAINED

SHELVES 3

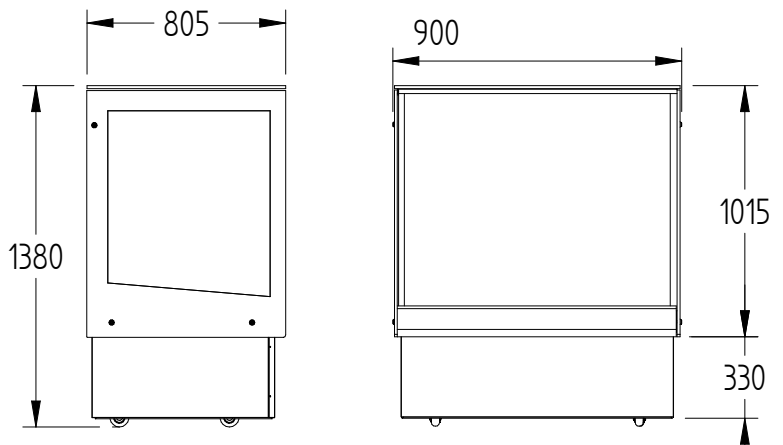
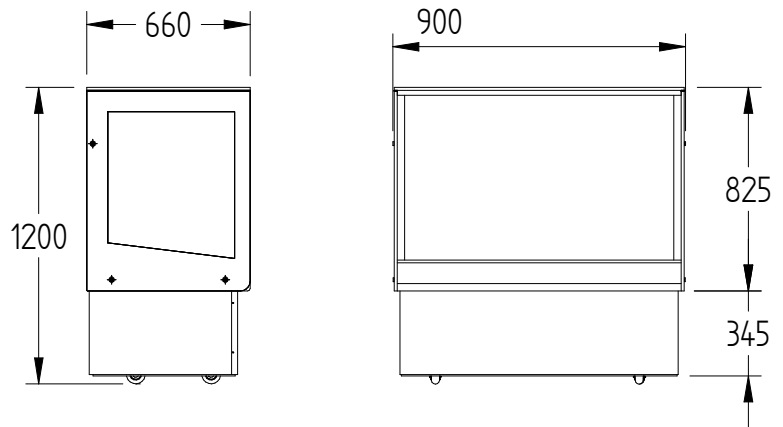

SPECIFICATIONS

DIMENSIONS - W X D X H (ON CASTORS) MM	900 W x 660 D x 1200 H
TEMPERATURE	1°C / 4°C
WEIGHT UNPACKED (KG)	220
DOOR TYPE	Standard: SL (Sliding Rear Doors)
FINISH	SS (Stainless Steel exterior)
SHELVES (INCLUDING BASE)	3

ELECTRICAL

POWER SUPPLY	10 amp	
HTC MODELS	RUNNING AMPS	3.0

GAS TYPE

REFRIGERANT	FRIDGE MODELS	R134a
--------------------	----------------------	-------

*** For **OPTIONS** refer to the current Williams Price Guide