



Thanks to a continuous and regular flow, the water is distributed on a refrigerated surface designed to increase ice production. Three different sizes are available **FULL DICE, HALF DICE** and **LARGE DICE**

High production modular ice maker.  
Up to 215kg production per 24/hr of dice cube.  
Head only, stainless steel cabinet.  
Complete with water & drain hoses.  
10 AMP power supply.



## ICE PRODUCTION

### Air Cooled Unit

Air Temp.		Water Temperature			
		32°	21°	15°	10°
°C					
°F					
10°		<b>185</b>	<b>215</b>	<b>230</b>	<b>240</b>
50°		408	474	507	529
21°		<b>175</b>	<b>200</b>	<b>215</b>	<b>220</b>
70°		386	441	474	485
32°		<b>135</b>	<b>155</b>	<b>160</b>	<b>165</b>
90°		298	342	353	365
38°		<b>120</b>	<b>133</b>	<b>138</b>	<b>140</b>
100°		265	293	302	309

### Water Cooled Unit

Air Temp.		Water Temperature			
		32°	21°	15°	10°
°C					
°F					
10°		<b>175</b>	<b>200</b>	<b>215</b>	<b>220</b>
50°		386	441	474	485
21°		<b>170</b>	<b>195</b>	<b>210</b>	<b>215</b>
70°		375	430	463	474
32°		<b>160</b>	<b>185</b>	<b>192</b>	<b>197</b>
90°		353	408	423	434
38°		<b>155</b>	<b>180</b>	<b>185</b>	<b>190</b>
100°		342	397	408	419

## CUBE TYPE

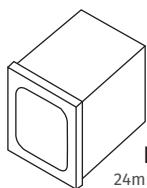

**10g**  
**FULL CUBE**  
24mm x 22mm x 22mm

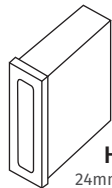

**6g**  
**HALF CUBE**  
24mm x 10mm x 29mm

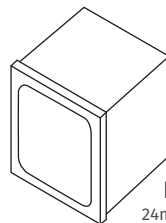

**17g**  
**LARGE CUBE**  
24mm x 29mm x 29mm

Solid ice cube, suitable for quick drink cooling, available in three different sizes, **FULL DICE (M models)**, **HALF DICE (MH models)** and **LARGE DICE (ML models)**, can be used in various applications: ice buckets, whisky on the rocks and cocktails.

## CONTROL PANEL

	Power
	Operating
	Bin Full / Washing
	Alarm
	High Pressure Alarm
	Reset Button / Washing

## SUGGESTED STORAGE BIN



BH76  
Stainless steel storage bin.  
244kg capacity.

## DIMENSIONS

W x D x H (mm)  
760 x 620 x 575

## OPERATING REQUIREMENTS

Rejected Heat	2432 W
Air Volume	590 m <sup>3</sup> /h















220-240/50/1



R404a GWP=3922

MIN		MAX
10°C (50°F)		40°C (104°F)
5°C (41°F)		35°C (95°F)
- 10 %		+ 10 %
1 Bar (14 psi)		5 Bar (70 psi)

## SPECIFICATIONS

	 cond	 comp. W	 ABS. W	 Fuse	 kWh/100kg	 L / hr	 kg	 lbs	 kg	 lbs	 Ton CO2 equiv.
<b>M202 A</b>		2348	1100	16	14.8	12	70	154	85	187	2.75
<b>M202 W</b>		2348	1000	16	10.6	128	70	154	85	187	1.96

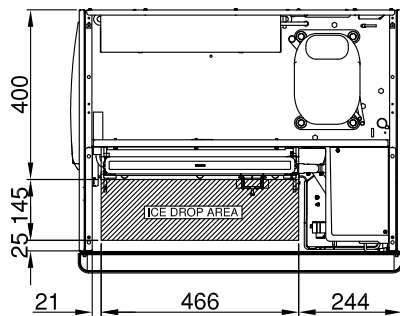
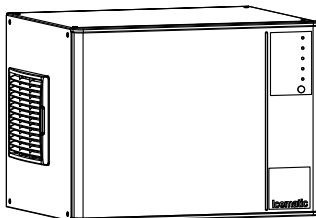
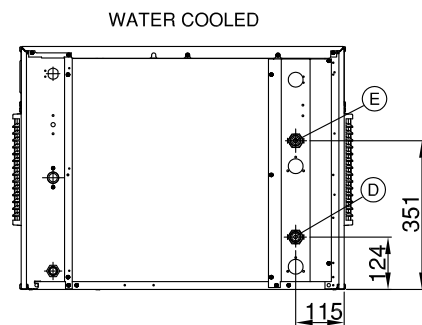
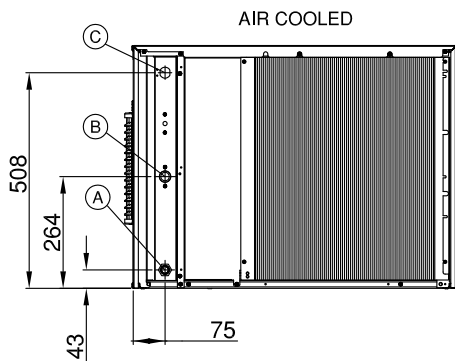
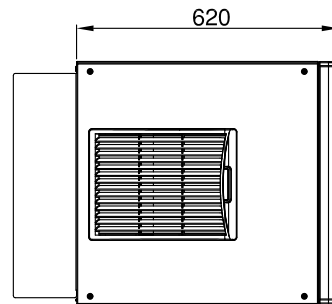
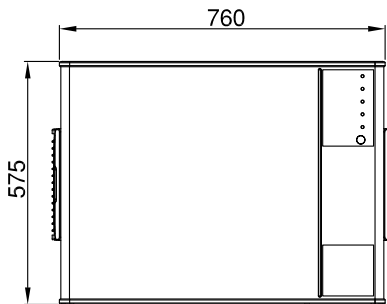

- A** Water drain 20mm diam.
- B** Potable water inlet 3/4" gas
- C** Electrical cable supply
- D** Water cooled inlet 3/4" gas
- E** Water cooled outlet 3/4" gas