

# HTU2SDSS-12



CATEGORY TOPAZ CAFÉ RANGE

RANGE **Topaz  
Under Counter**

UNIT REFRIGERATOR

TYPE SELF CONTAINED

DOORS 2

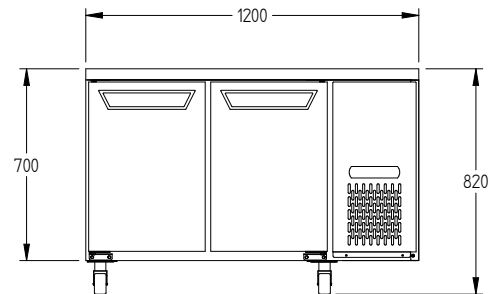
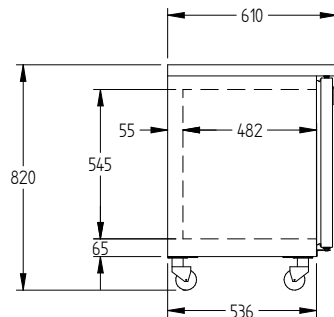
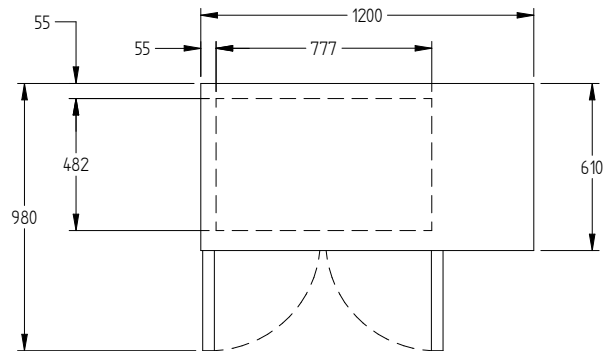

## SPECIFICATIONS

TEMPERATURE - 38°C AMBIENT ENVIRONMENT	1°C / 4°C
CAPACITY LITRES	210
DIMENSIONS - W X D X H (ON LEGS) MM	1200 W x 610 D x 800 H
WEIGHT UNPACKED (KG)	120
DOOR TYPE	SD (Solid Door)
FINISH (INTERIOR AND EXTERIOR EXCLUDING REAR AND UNDER)	SS (Stainless Steel)
SHELVES/DOOR	2
<b>ELECTRICAL</b>	
POWER SUPPLY	10 amp
POWER CABLE LENGTH (METRES)	2
RUNNING AMPS	2.5
<b>GAS TYPE</b>	
REFRIGERANT	134a

\*\*\* For **OPTIONS** refer to the current Williams Price Guide