

HTG1SS

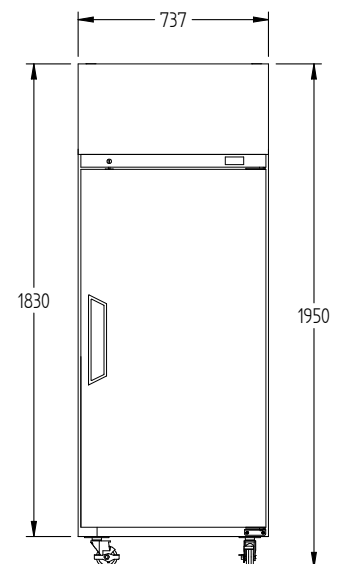

CATEGORY	TOPAZ CAFÉ RANGE
RANGE	Topaz Top Mount
UNIT	REFRIGERATOR
TYPE	SELF CONTAINED
DOORS	1

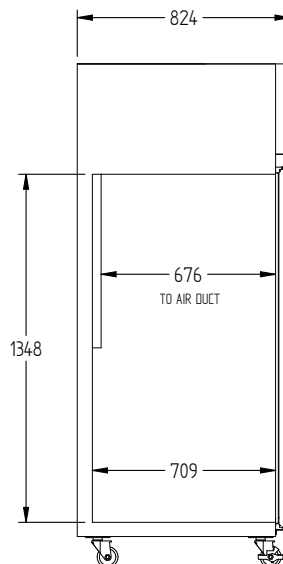
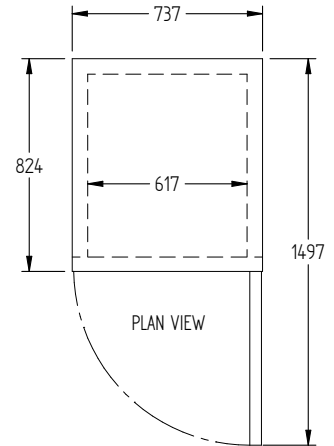

SPECIFICATIONS

TEMPERATURE	1°C / 4°C
CAPACITY LITRES	550
DIMENSIONS - W X D X H MM	737 W x 824 D x 1950 H
WEIGHT UNPACKED (KG)	170
STANDARD INCLUSIONS	
DOOR TYPE	S (SOLID DOOR)
FINISH (INTERIOR AND EXTERIOR EXCLUDING REAR AND UNDER)	S (STAINLESS STEEL)
SHELVES/DOOR	4

ELECTRICAL

POWER SUPPLY	10amp
RUNNING AMPS	2.6

GAS TYPE

REFRIGERANT	R134a
-------------	-------

*** For **OPTIONS** refer to the current Williams Price Guide