

HTB3GB



CATEGORY TOPAZ CAFÉ RANGE

RANGE **Topaz
Bottle Cooler**

UNIT REFRIGERATOR

TYPE SELF CONTAINED

DOORS 3

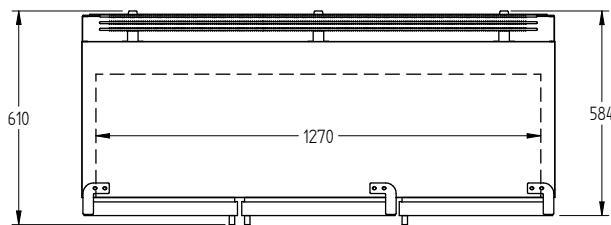

TOP VIEW

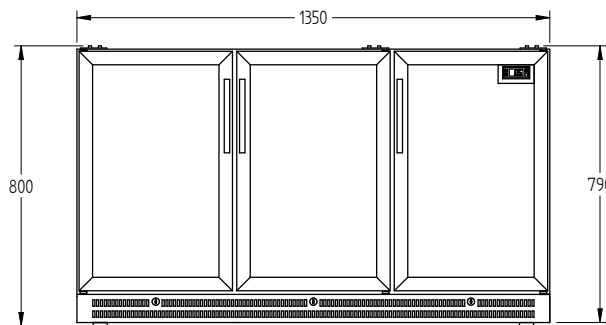

FRONT VIEW

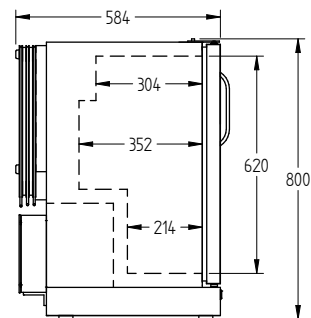

SIDE VIEW

SPECIFICATIONS

TEMPERATURE	4°C / 10°C
CAPACITY LITRES	240
DIMENSIONS - W X D X H (BC) MM	1350 W x 584 D x 800 H
WEIGHT UNPACKED (KG)	118
DOOR TYPE	G (Glass Door)
FINISH (INTERIOR AND EXTERIOR EXCLUDING REAR AND UNDER)	B (Black)
SHELVES/DOOR	2
ELECTRICAL	
POWER SUPPLY	10 amp
RUNNING AMPS	3.1
GAS TYPE	
REFRIGERANT	R134a

*** For **OPTIONS** refer to the current Williams Price Guide